

MLG-45PDB Installation Manual

Stack Dryer

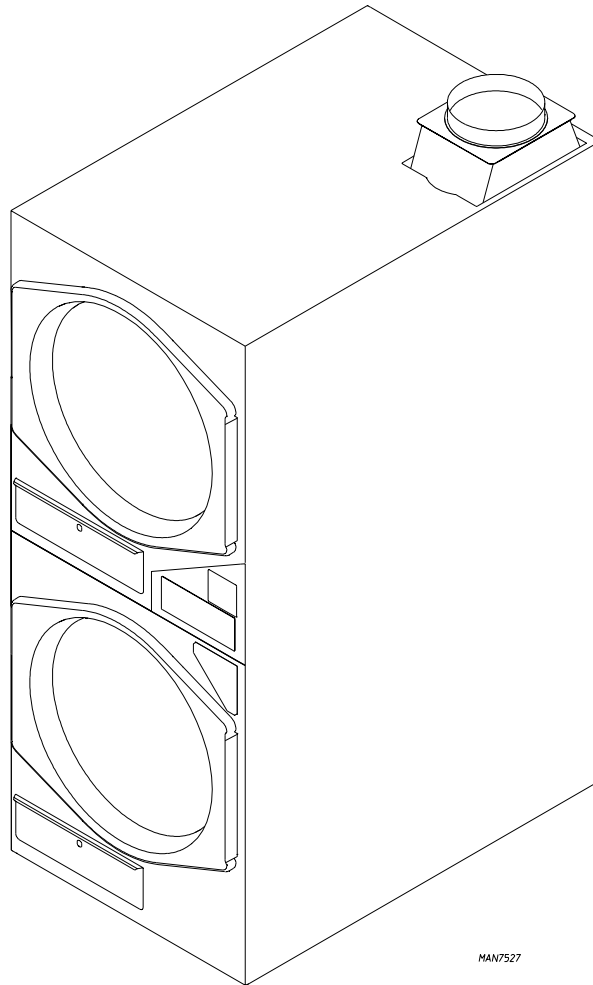

MAN7527



**RETAIN THESE
INSTRUCTIONS IN A
SAFE PLACE FOR
FUTURE REFERENCE**

Part No. 113489-5 (W10185535)

Dryer Safety

Your safety and the safety of others are very important.

We have provided many important safety messages in this manual and on your appliance. Always read and obey all safety messages.



This is the safety alert symbol.

This symbol alerts you to potential hazards that can kill or hurt you and others.

All safety messages will follow the safety alert symbol and either the word “DANGER” or “WARNING”.

These words mean:

⚠ DANGER

You can be killed or seriously injured if you don't immediately follow instructions.

⚠ WARNING

You can be killed or seriously injured if you don't follow instructions.

All safety messages will tell you what the potential hazard is, tell you how to reduce the chance of injury, and tell you what can happen if the instructions are not followed.

- It is recommended that the owner post, in a prominent location, instructions for the customer's use in the event the customer smells gas. This information should be obtained from your gas supplier.

- Post the following warning in a prominent location.

FOR YOUR SAFETY

Do not store or use gasoline or other flammable vapors and liquids in the vicinity of this or any other appliance.

POUR VOTRE SÉCURITÉ

Ne pas entreposer ni utiliser d'essence ni d'autres vapeurs ou liquides inflammables à proximité de cet appareil ou de tout autre appareil.

WARNING: For your safety the information in this manual must be followed to minimize the risk of fire or explosion or to prevent property damage, personal injury or death.

AVERTISSEMENT: Assurez-vous de bien suivre les instructions données dans cette notice pour réduire au minimum le risque d'incendie ou d'explosion ou pour éviter tout dommage matériel, toute blessure ou la mort.

- Do not store or use gasoline or other flammable vapors and liquids in the vicinity of this or any other appliance.
- **WHAT TO DO IF YOU SMELL GAS:**
 - Do not try to light any appliance.
 - Do not touch any electrical switch; Do not use any phone in your building.
 - Clear the room, building or area of all occupants.
 - Immediately call your gas supplier from a neighbor's phone. Follow the gas supplier's instructions.
 - If you cannot reach your gas supplier, call the fire department.
- Installation and service must be performed by a qualified installer, service agency or the gas supplier.

- Ne pas entreposer ni utiliser d'essence ni d'autres vapeurs ou liquides inflammables à proximité de cet appareil ou de tout autre appareil.
- **QUE FAIRE SI VOUS SENTEZ UNE ODEUR DE GAZ:**
 - Ne pas tenter d'allumer d'appareils.
 - Ne touchez à aucun interrupteur; Ne pas vous servir des téléphones se trouvant dans le bâtiment.
 - Évacuez la pièce, le bâtiment ou la zone.
 - Appelez immédiatement votre fournisseur de gaz depuis un voisin. Suivez les instructions du fournisseur.
 - Si vous ne pouvez rejoindre le fournisseur de gaz, appelez le service des incendies.
- L'installation et l'entretien doivent être assurés par un installateur ou un service d'entretien qualifié ou par le fournisseur de gaz.

WARNING: Gas leaks cannot always be detected by smell.

Gas suppliers recommend that you use a gas detector approved by UL or CSA.

For more information, contact your gas supplier.

If a gas leak is detected, follow the “What to do if you smell gas” instructions.

In the State of Massachusetts, the following installation instructions apply:

- Installations and repairs must be performed by a qualified or licensed contractor, plumber, or gasfitter qualified or licensed by the State of Massachusetts.
- If using a ball valve, it shall be a T-handle type.
- A flexible gas connector, when used, must not exceed 3 feet.

State of California Proposition 65 Warnings:

WARNING: This product contains a chemical known to the State of California to cause cancer.

WARNING: This product contains a chemical known to the State of California to cause birth defects or other reproductive harm.

IMPORTANT SAFETY INSTRUCTIONS

WARNING: To reduce the risk of fire, electric shock, or injury to persons when using the dryer, follow basic precautions, including the following:

- Read all instructions before using the dryer.
- Do not place items exposed to cooking oils in your dryer. Items contaminated with cooking oils may contribute to a chemical reaction that could cause a load to catch fire.
- Do not dry articles that have been previously cleaned in, washed in, soaked in, or spotted with gasoline, dry-cleaning solvents, other flammable, or explosive substances as they give off vapors that could ignite or explode.
- Do not allow children to play on or in the dryer. Close supervision of children is necessary when the dryer is used near children.
- Before the dryer is removed from service or discarded, remove the door to the drying compartment.
- Do not reach into the dryer if the drum is moving.
- Do not install or store the dryer where it will be exposed to the weather.
- Do not tamper with controls.
- Do not repair or replace any part of the dryer or attempt any servicing unless specifically recommended in this installation manual or in published user-repair instructions that you understand and have the skills to carry out.
- Do not use fabric softeners or products to eliminate static unless recommended by the manufacturer of the fabric softener or product.
- Do not use heat to dry articles containing foam rubber or similarly textured rubber-like materials.
- Clean lint screen every third load to fourth.
- Keep area around the exhaust opening and adjacent surrounding areas free from the accumulation of lint, dust, and dirt.
- The interior of the dryer and exhaust vent should be cleaned periodically by qualified service personnel.
- See installation instructions for grounding requirements.

SAVE THESE INSTRUCTIONS

IMPORTANT: The gas installation must conform with local codes, or in the absence of local codes, with the National Fuel Gas Code, ANSI Z223.1/NFPA 54 or the Canadian Natural Gas and Propane Installation Code, CSA B149.1.

The dryer must be electrically grounded in accordance with local codes, or in the absence of local codes, with the National Electrical Code, ANSI/NFPA 70 or Canadian Electrical Code, CSA C22.1.

Important Information

IMPORTANT: A means of restraint must be used to prevent straining of the gas supply when the dryer is moved.

An external means of power removal (disconnect device) must be provided by the installer.

“Caution: Label all wires prior to disconnection when servicing controls. Wiring errors can cause improper operation.”

«Attention: Au moment de l'entretien des commandes, étiquetez tous les fils avant de les débrancher. Des erreurs de câblage peuvent entraîner un fonctionnement inadéquat et dangereux.»

WARNING

The dryer must never be operated with any of the back guards or service panels removed. Personal injury or fire could result.

The wiring diagram for the dryer is located behind the front control panel on the right side.

List of Acronyms

AWG	American Wire Gauge
HVAC	Heating, Ventilating, and Air-Conditioning
in wc	Inches of Water Column
L.C.D.	Liquid Crystal Display
L.E.D.	Light Emitting Diode
L.P.	Liquid Propane
UL	Underwriters Laboratory

Table of Contents

SPECIFICATIONS	5
INSTALLATION PROCEDURES	6
Location Requirements	6
Dryer Enclosure Requirements	7
Fresh Air Supply Requirements	7
Exhaust Requirements	7
Electrical Information	10
Gas Information	11
Preparation for Operation/Start-Up	12
Preoperational Test	13
Operating Instructions	13
Shutdown Instructions	13
SERVICE/PARTS INFORMATION	13
Service	13
Parts	13
ROUTINE MAINTENANCE	13
Cleaning	13
Adjustments	14
DATA LABEL INFORMATION	14

Specifications

MAXIMUM CAPACITY (DRY WEIGHT) PER POCKET		45 lb	20.41 kg	
TUMBLER DIAMETER		32-3/4"	83.19 cm	
TUMBLER DEPTH		30"	76.20 cm	
TUMBLER VOLUME PER POCKET		14.6 cu ft	413.43 L	
TUMBLER/DRIVE MOTOR PER POCKET		3/4 hp	0.56 kW	
BLOWER/FAN MOTOR PER POCKET		BLOWER DRIVEN BY TUMBLER MOTOR		
DOOR OPENING (DIAMETER)		27"	68.58 cm	
DOOR SILL HEIGHT TOP POCKET / BOTTOM POCKET		50-1/4" / 10-1/4"	127.64 cm / 26.04 cm	
DRYERS PER 20'/40' CONTAINER		8 / 16		
DRYERS PER 48'/53' TRUCK		25 / 27		
Gas	VOLTAGE AVAILABLE	120/240V 1Ø 2w 50/60 Hz		
	APPROXIMATE NET WEIGHT	1,015 lb	460.40 kg	
	APPROXIMATE SHIPPING WEIGHT	1,080 lb	489.88 kg	
	AIRFLOW PER POCKET	60 Hz	600 cfm	16.99 cmm
		50 Hz	500 cfm	14.16 cmm
	HEAT INPUT PER POCKET	112,000 Btu/hr		28,224 kcal/hr
	EXHAUST CONNECTION (DIAMETER) PER POCKET	(2) 8" Standard (1) 10" Optional		(2) 20.32 cm (1) 25.4 cm
INLET PIPE CONNECTION		3/4" M.N.P.T.		

8/2/07

NOTE: The manufacturer reserves the right to make changes in specifications at any time without notice or obligation.

DRYER NOTES:

- * DUCTWORK SIZE VARIES WITH INSTALLTION CONDITIONS.
- * EXHAUST STATIC PRESSURE MUST BE NO LESS THAN 0 AND MUST NOT EXCEED .6 INCHES WATER COLUMN (1.48 mBAR).

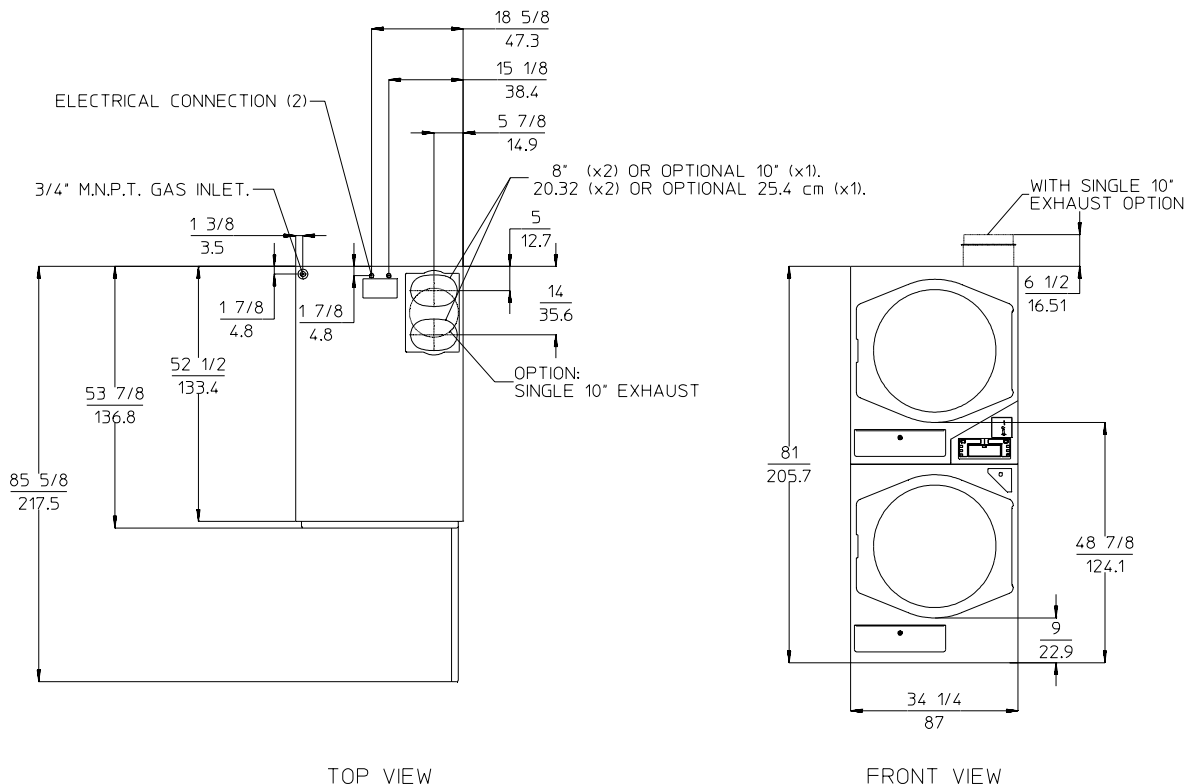

5/24/07

Installation Procedures

⚠ WARNING

Excessive Weight Hazard

Use two or more people and mechanical equipment to lift, move and install dryer.

Failure to do so can result in back or other injury.

Installation should be performed by competent professional in accordance with local, state, and country codes. In the absence of these codes, the installation must conform to applicable American National Standards: ANSI Z223.1-LATEST EDITION (National Fuel Gas Code) or ANSI/NFPA NO. 70-LATEST EDITION (National Electrical Code) or in Canada, the installation must conform to applicable Canadian Standards: CAN/CGA-B149.1-M91 (Natural Gas) or CAN/CGA-B149.2-M91 (L.P. Gas) or LATEST EDITION (for General Installation and Gas Plumbing) or Canadian Electrical Codes Parts 1 & 2 CSA C22.1-1990 or LATEST EDITION (for Electrical Connections).

Leveling Dryer

The dryer is equipped with 4 leveling legs, 1 at each corner of the base. For optimum performance the dryer should be level front-to-back and side-to-side.

Tools Required

- Utility Knife to remove packaging
- 9/16" Box wrench or 9/16" socket to remove pallet bolts
- #2 Phillips screwdriver to open box cover
- Pipe wrench for gas connections
- 7/8" open end wrench or adjustable wrench to install coin box lock

Leveling feet adjustment

- TORX® T20 TORX® T25 to open front and rear to get foot adjustment ends
- 1/4" socket or 1/4" open end wrench to make the adjustment

®TORX is a registered trademark of Textron Innovations, Inc.

Location Requirements

⚠ WARNING



Explosion Hazard

Keep flammable materials and vapors, such as gasoline, away from dryer.

Do not install in a garage.

Failure to do so can result in death, explosion, or fire.

Before installing the dryer, be sure the location conforms to local codes and ordinances. In the absence of such codes or ordinances the location must conform with the National Fuel Gas Code ANSI.Z223.1 LATEST EDITION, or in Canada, the installation must conform to applicable Canadian Standards: CAN/CGA-B149.1-M91 (Natural Gas) or CAN/CGA-B149.2-M91 (L.P. Gas) or LATEST EDITION (for General Installation and Gas Plumbing).

The operation of this dryer may affect the operation of other types of gas dryers, which take their air for safe combustion from the same room. If in doubt, consult the dryer manufacturer(s).

The dryer must be installed on a sound level floor capable of supporting its weight. Carpeting must be removed from the floor area that the dryer is to rest on.

Provisions for adequate air supply must be provided as noted in this manual (refer to Fresh Air Supply Requirements section).

Clearance provisions must be made from combustible construction as noted in this manual (refer to Dryer Enclosure Requirements section).

Provisions must be made for adequate clearances for servicing and for operation as noted in this manual (refer to Dryer Enclosure Requirements section).

The dryer must be installed with a proper exhaust duct connection to the outside as noted in this manual (refer to Exhaust Requirements section).

The dryer must be located in an area where correct exhaust venting can be achieved as noted in this manual (refer to Exhaust Requirements section).

IMPORTANT: *The dryer should be located where a minimum amount of exhaust ducting will be necessary.*

The dryer must be installed with adequate clearance for air openings into the combustion chamber.

IMPORTANT: *The dryer must be installed in a location/ environment, which the ambient temperature remains between 40° F (4.44° C) and 130° F (54.44° C).*

Dryer Enclosure Requirements

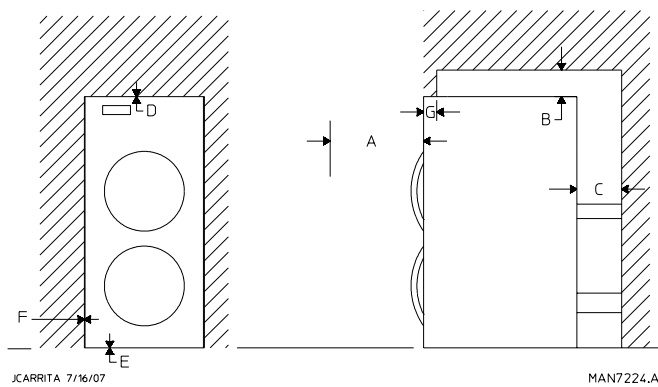

- A The requirement to allow the dryer door to open completely is 33.5-inches (85.1 cm).
- B A minimum overhead clearance of 12-inches (30.48 cm) is required.
- C Dryer should be positioned a minimum of 12-inches (30.48 cm) away from the nearest obstruction. 24-inches (60.96 cm) is recommended for ease of installation, maintenance, and service.
- D 1/16" (1.5875 mm) minimum is required.
- E Flooring should be level or below dryer cabinet for ease of removing panels during maintenance.
- F Dryers may be positioned sidewall to sidewall, however a 1/16" (1.5875 mm) minimum allowance must be made for the opening and closing of the control door, along with the removal of panels during maintenance.
- G 4-inch (10.16 cm) maximum.

Fresh Air Supply Requirements

When the dryer is operating, it draws in room air, heats it, passes this air through the tumbler, and exhausts it out of the building. Therefore, the room air must be continually replenished from the outdoors. If the make-up air is inadequate, drying time and drying efficiency will be adversely affected. Ignition problems and sail switch "fluttering" problems may result, as well as premature motor failure from overheating. The dryer must be installed with provisions for adequate combustion and make-up air supply.

Air supply (make-up air) must be given careful consideration to ensure proper performance of each dryer. Fresh air ventilation openings shall not be blocked and/or sealed. As a general rule, an unrestricted air entrance from the outdoors of 224 inch² (1,445 cm²) is required for each dryer. (Based on 1 inch² [6.5 cm²] per 1,000 Btu [252 kcal].)

It is not necessary to have a separate make-up air opening for each dryer. Common make-up air openings are acceptable. However, they must be set up in such a manner that the make-up air is distributed equally to all the dryers.

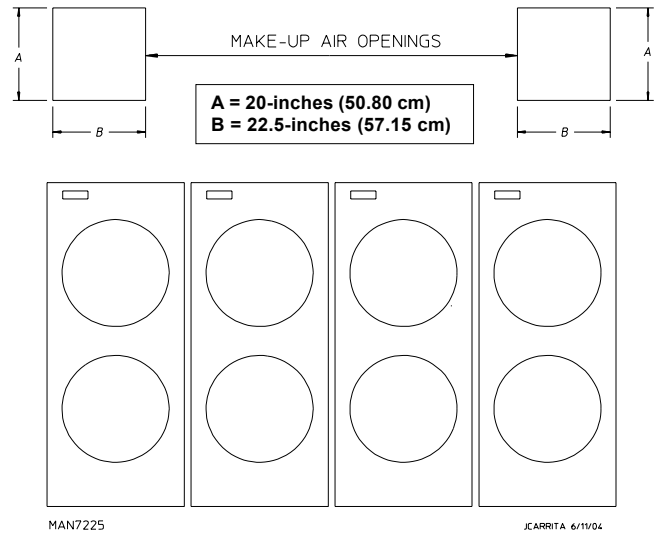

EXAMPLE: For a bank of 4 dryers, 2 unrestricted openings measuring 20-inches by 22.5-inches (50.80 cm by 57.15 cm) are acceptable.

To compensate for the use of registers or louvers used over the openings, this area must be increased by approximately 33%. Make-up air openings should not be located in an area directly near where exhaust vents exit the building.

Allowances must be made for remote or constricting passageways or where dryers are located at high altitudes or predominantly low pressure areas.

IMPORTANT: Make-up air must be free of dry cleaning solvent fumes. Make-up air that is contaminated by dry cleaning solvent fumes will result in irreparable damage to the motors and other dryer components.

NOTE: Component failure due to dry cleaning solvent fumes will void the warranty.

Exhaust Requirements

Exhaust ductwork should be designed and installed by a qualified professional. Improperly sized ductwork will create excessive back pressure, which results in slow drying, increased use of energy, and shutdown of the burner by the airflow (sail) switch, burner hi-limits, or lint chamber hi-limit protector thermostat. The dryer must be installed with a proper exhaust duct connection to the outside.

⚠ WARNING

Fire Hazard

- Use a heavy metal vent.**
- Do not use a plastic vent.**
- Do not use a metal foil vent.**
- Failure to follow these instructions can result in death or fire.**

As per the National Fuel Gas Code, "Exhaust ducts for type 2 clothes dryers shall be constructed of sheet metal or other noncombustible material. Such ducts shall be equivalent in strength and corrosion resistance to ducts made of galvanized sheet steel not less than 26 gauge (0.0195-inches [0.50 mm]) thick."

The ductwork should be laid out in such a way that the ductwork travels as directly as possible to the outdoors with as few turns as possible. Single or independent dryer venting is recommended. It is suggested that the use of 90° turns be avoided; use 30° and/or 45° bends instead. The radius of the elbows should preferably be 1-1/2 times the diameter of the duct. All ductwork should be smooth inside with no projections from sheet metal screws or other obstructions, which will collect lint. When adding ducts, overlap the duct being connected. All ductwork joints must be taped to prevent moisture and lint from escaping into the building. Inspection doors should be installed at strategic points in the exhaust ductwork for periodic inspection and cleaning of lint from the ductwork.

IMPORTANT: It is recommended that exhaust or booster fans not be used in the exhaust ductwork system.

Exhaust back pressure measured by a manometer/magnehelic in the exhaust duct must be no less than 0 and must not exceed 0.6 in wc (1.48 mb).

NOTE: When the exhaust ductwork passes through a wall, ceiling, or roof made of combustible materials, the opening must be 2-inches (5.08 cm) larger than the duct (all the way around). The duct must be centered within this opening.

The ductwork for this dryer must be suitable for the appliance category in accordance with national installation regulations of the country of destination.

Outside Ductwork Protection

To protect the outside end of the horizontal ductwork from the weather, a 90° elbow bent downward should be installed where the exhaust exits the building. If the ductwork travels vertically up through the roof, it should be protected from the weather by using a 180° turn to point the opening downward. In either case, allow at least twice the diameter of the duct between the duct opening and the nearest obstruction (refer to the diagram).

IMPORTANT: Do not use screens, louvers, or caps on the outside opening of the exhaust ductwork.

Single Dryer Venting with Transition Piece

IMPORTANT: For extended ductwork runs, the cross-sectional area of the ductwork can only be increased to an extent. When the ductwork approaches the maximum limits as noted in this manual, a professional HVAC firm should be consulted for proper venting information.

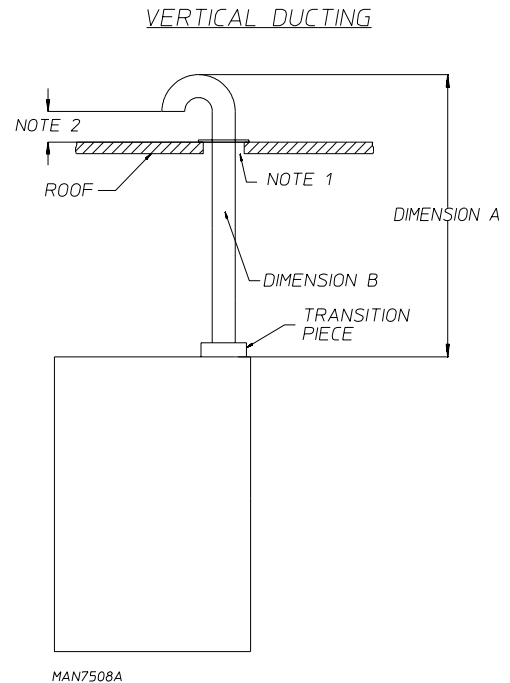
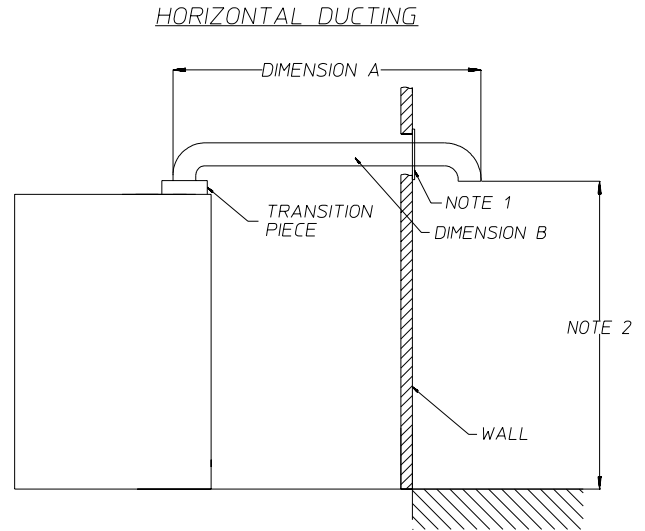

NOTE 1 Opening from combustible materials must be 2-inches (5.08 cm) larger than the duct (all the way around). The duct must be centered within this opening.

NOTE 2 Distance should be 2 times the diameter of the duct to the nearest obstruction.

Single Dryer Venting without Transition Piece

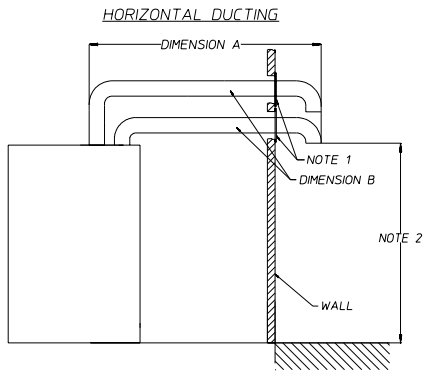

A = 20 feet (6.10 meters)
B = 8-inches (20.32 cm)

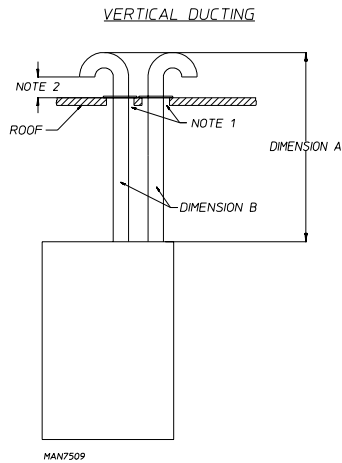

The length of the ductwork from the dryer to the outside exhaust outlet must not exceed 20 feet (6.09 meters). The minimum diameter of this ductwork must be at least 8-inches (20.32 cm) when each pocket/tumbler is vented individually and 10-inches (25.4 cm) when both pockets/tumblers are combined. Including tumbler/dryer elbow connections or elbows used for outside protection from the weather, no more than 2 90° elbows should be used in the exhaust duct run. If more than the equivalent of 2 90° elbows are used, the cross-sectional area of the ductwork must be increased.

Multiple Dryer (Common) Venting

IMPORTANT: For extended ductwork runs, the cross-sectional area of the ductwork can only be increased to an extent. When the ductwork approaches the maximum limits as noted in this manual, a professional HVAC firm should be consulted for proper venting information.

If it is not feasible to provide separate exhaust ducts for each dryer, ducts from individual dryers may be channeled into a "common main duct." The individual ducts should enter the bottom or side of the main duct at an angle not more than 45° in the direction of airflow. The main duct should be tapered, with the diameter increasing before each individual duct is added. The minimum diameter of the individual ductwork must be at least 8-inches (20.32 cm) for individual pockets/tumblers or 10-inches (25.4 cm) for individual dryers.

IMPORTANT: To maintain proper performance, no more than 4 dryers should be connected to 1 main common duct.

The illustration below shows the minimum cross-sectional area for multiple dryer round or square venting. These figures must be increased if the main duct run from the last dryer to where it exhausts to the outdoors is longer than 20 feet (6.09 meters) or has more than 1 elbow in it.

Multiple Dryer Venting with 10-Inch (25.4 cm) Diameter
 1,200 cfm (33.98 cmm) Exhaust Connections at Common Duct

NUMBER OF DRYERS	4	3	2	1	
MINIMUM CROSS-SECTIONAL AREA	SQ IN	254	200	155	80
	SQ CM	1638	1290	999	516
MINIMUM ROUND DUCT DIAMETER	IN	18	16	14	10
	CM	45.72	40.64	35.56	25.4

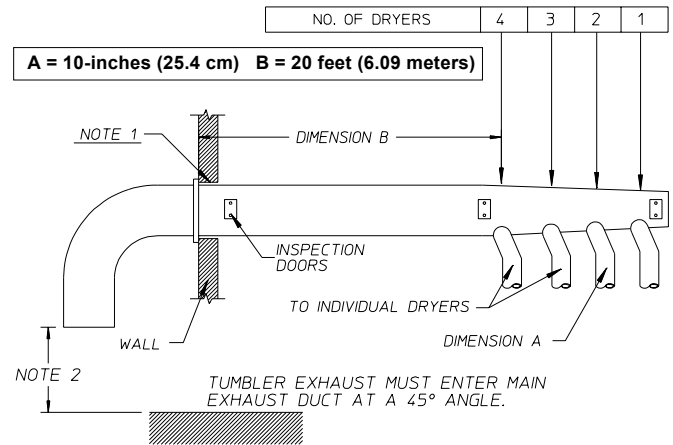

JCARRITA 04/21/04

MAN7212

NOTE 1 Opening from combustible materials must be 2-inches (5.08 cm) larger than the duct (all the way around). The duct must be centered within this opening.

NOTE 2 Distance should be 2 times the diameter of the duct to the nearest obstruction.

Multiple Dryer Venting with 8-Inch (20.32 cm) Diameter
 600 cfm (16.99 cmm) Exhaust Connections at Common Duct

NUMBER OF DRYERS	8	7	6	5	4	3	2	1
MINIMUM CROSS-SECTIONAL AREA	SQ IN	254	200	155	80			
	SQ CM	1638	1290	999	516			
MINIMUM ROUND DUCT DIAMETER	IN	18	16	14	10			
	CM	45.72	40.64	35.56	25.4			

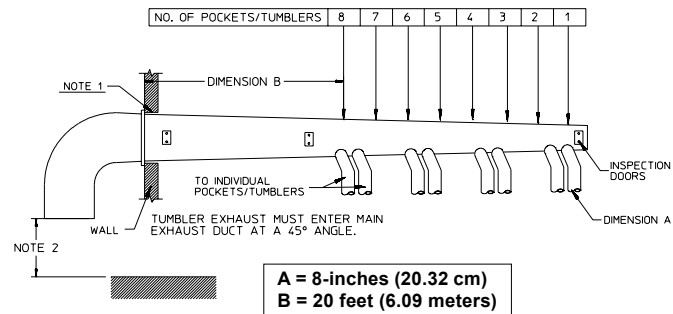

JCARRITA 7/16/07

MAN7510

NOTE 1 Opening from combustible materials must be 2-inches (5.08 cm) larger than the duct (all the way around). The duct must be centered within this opening.

NOTE 2 Distance should be 2 times the diameter of the duct to the nearest obstruction.

Electrical Information

Electrical Requirements

All electrical connections must be made by a properly licensed and competent electrician. This is to ensure that the electrical installation is adequate and conforms to local, state, and national regulations or codes of the country of destination. In the absence of such codes, all electrical connections, materials, and workmanship must conform to the applicable requirements of the National Electrical Code ANSI/NFPA NO. 70-LATEST EDITION or in Canada, the Canadian Electrical Codes Parts 1 & 2 CSA C22.1-1990 or LATEST EDITION.

For personal safety, the dryer must be electrically grounded in accordance with local codes and/or the National Electrical Code ANSI/NFPA NO. 70-LATEST EDITION or in Canada, the Canadian Electrical Codes Parts 1 & 2 CSA C22.1-1990 or LATEST EDITION.

IMPORTANT: Failure to comply with these codes or ordinances, and/or the requirements stipulated in this manual can result in personal injury or component failure.

NOTE: Component failure due to improper installation will void the warranty.

Each pocket should be connected to an independently protected branch circuit. The dryer must be connected with copper wire only. Do not use aluminum wire. The copper conductor wire/cable must be of proper ampacity and insulation in accordance with electric codes for making all service connections.

NOTE: The use of aluminum wire will void the warranty.

An individual ground circuit must be provided to each pocket, do not daisy chain.

Component failure due to improper voltage application will void the warranty.

The manufacturer reserves the right to make changes in specifications at any time without notice or obligation.

IMPORTANT: A separate protected circuit must be provided to each pocket.

It is necessary to have a power disconnect for each pocket. These disconnects must be located within 30 feet (9 meters) of the dryer and also be identified as being one of two power sources supplying a dryer.

The dryer must be connected to the electric supply shown on the data label.

Electrical Service Specifications

ELECTRICAL SERVICE SPECIFICATIONS (PER POCKET)						
SERVICE VOLTAGE	PHASE	WIRE SERVICE	APPROX. AMP DRAW		MINIMUM WIRE SIZE*	CIRCUIT BREAKER
			60 Hz	50 Hz		
120	1Ø	2	12	—	14	15

NOTES: A. When fuses are used they must be dual element, time delay, current limiting, class RK1 or RK5 ONLY. Calculate/determine correct fuse value, by applying either local and/or National Electrical Codes to listed appliance amp draw data.
B. Circuit breakers are thermal-magnetic (industrial) motor curve type ONLY. For others, calculate/verify correct breaker size according to appliance amp draw rating and type of breaker used.

* AWG standard type wire ... for individual lengths less than 100 feet (30.48 meters). 9/18/08

Grounding

A ground (earth) connection must be provided and installed in accordance with local, state, and national regulations or codes of the country of destination. In the absence of these codes, grounding must conform to applicable requirements of the National Electrical Code ANSI/NFPA NO. 70-LATEST EDITION, or in Canada, the installation must conform to applicable Canada Standards: Canadian Electrical Codes Parts 1 & 2 CSA C22.1-1990 or LATEST EDITION. The ground connection may be to a proven earth ground at the location service panel.

Electrical Connections

If local codes permit, power to the dryer can be made by the use of a flexible UL listed power cord/pigtail (wire size must conform to rating of dryer), or the dryer can be hard wired directly to the service breaker panel. In both cases, a strain relief must be installed where the wiring enters the dryer.

⚠ WARNING



Fire Hazard

Use 10 gauge solid copper wire.

Use a UL listed strain relief.

Determine the top pocket electrical connections by checking wire label, which will be marked "top".

Connect the top pocket white wire to the white wire from the top pocket 15-amp service; Connect the top pocket black wire to the black wire from the top pocket 15-amp service; Connect the top pocket green wire to the green wire from the top pocket ground connection.

The remaining wires will be the bottom pocket connect as follows:

Connect the bottom pocket white wire to the white wire from the bottom pocket 15-amp service; Connect the bottom pocket black wire to the black wire from the bottom pocket 15-amp service; Connect the bottom pocket green wire to the green wire from the bottom pocket ground connection.

Securely tighten all electrical connections.

Failure to do so can result in death, fire, or electrical shock.

Single-Phase (1Ø) Wiring Connections/ hookup

The electrical input connections are made into the rear service box located at the top rear of the dryer. To gain access, the service box cover must be removed.

120 Volt Application with Neutral

Remove 3 screws holding down electrical box plate at the top of the machine.

Remove 2 knockouts provided just in front of electrical box and insert 3/4" UL listed strain relief into the holes.

Insert the wiring from the two 120 volt 15 amp circuits (one for top tumbler and one for bottom tumbler) into the strain reliefs.

Determine the top pocket electrical connections by checking wire label, which will be marked "top".

Connect wiring from 120 volt 15 amp circuit to top pocket wiring as described in the following illustration (black to black, white to white and green to chassis ground wire).

Connect wiring from 120 volt 15 amp circuit to remaining wires (bottom pocket) as described in the following illustration (black to black, white to white and green to chassis ground wire).

Tighten strain relief screws assuring to leave a 1/2" of slack in box.

Replace electrical box plate by inserting 3 screws previously removed.

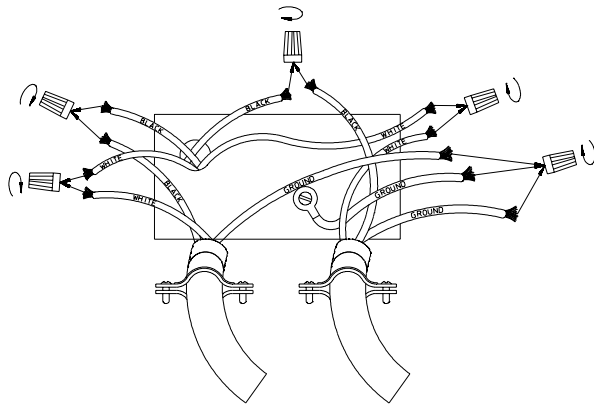

MAN7528

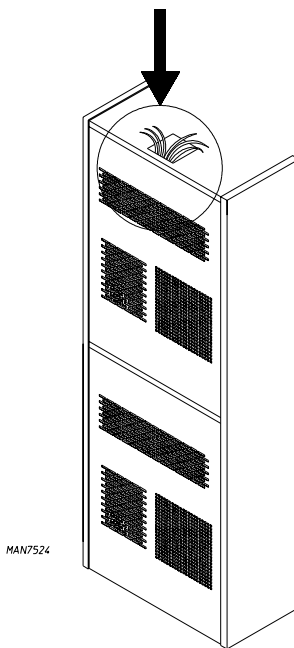

MAN7524

Single-Phase Electrical Connection Leads		
Black = L1	White = Neutral	Green = Ground

Input connection wiring must be sized properly to handle the dryer's current draw. This information is printed on the dryer's data label.

Gas Information

⚠ WARNING



Explosion Hazard

Use a new CSA International approved gas supply line.

Install a shutoff valve.

Securely tighten all gas connections.

Examples of a qualified person include:

licensed heating personnel,
authorized gas company personnel, and
authorized service personnel.

Failure to do so can result in death, explosion, or fire.

Type of Gas

This dryer is equipped for use with natural gas. It is design-certified by CSA International for L.P. (propane and butane) gases with appropriate conversion (L.P. kit 887168). No attempt shall be made to convert the dryer from the gas specified on the serial/rating plate for use with a different gas without consulting the serving gas supplier. Conversion must be done by a qualified service technician.

It is your responsibility to have all plumbing connections, materials, and workmanship conform to local and state regulations or codes of the country of destination. In the absence of such codes, all plumbing connections, materials, and workmanship must conform to the applicable local requirements. In the USA this is the National Fuel Gas Code ANSI Z223.1-LATEST EDITION, or in Canada, the Canadian Installation Codes CAN/CGA-B149.1-M91 (Natural Gas) or CAN/CGAB149.2-M91 (L.P. Gas) or LATEST EDITION.

It is important that gas pressure regulators meet applicable pressure requirements, and that gas meters be rated for the total amount of all the dryer Btu being supplied.

IMPORTANT: For ease of service, the individual gas supply line of each dryer must have its own manual shutoff valve.

The dryer must be isolated from the gas supply piping system by closing its individual manual shutoff valve during any pressure test of the gas supply system at test pressures equal to or less than 1/2 psig (3.5 kPa).

The dryer and its individual shutoff valve must be disconnected from the gas supply piping system during any pressure testing of that system at test pressures in excess of 1/2 psig (3.5 kPa).

Failure to isolate or disconnect the dryer from supply as noted can cause irreparable damage to the gas valve, voiding the warranty.

NOTE: Undersized gas piping will result in ignition problems, slow drying, and increased use of energy.

The input ratings shown on the data label are for elevations up to 2,000 feet (610 meters), unless elevation requirements of over 2,000 feet (610 meters) were specified at the time the dryer order was placed with the factory. The adjustment or conversion of dryers in the field for elevations over 2,000 feet (610 meters) is made by changing each burner orifice. If this conversion is necessary, contact the distributor who sold the dryer or contact the manufacturer.

IMPORTANT: If connection to this dryer is made with a flexible hose, it must be suitable for the appliance category in accordance with national installation regulations of the country of destination, and if in doubt the installer must contact the supplier. The manufacturer of this dryer does not recommend the use of flexible gas supply line/hose.

Pipe joint compounds that resist the action of natural, propane, and butane gases must be used.

In the U.S.A.: An individual manual shutoff valve must be installed within 6 feet (1.8 meters) of the dryer in accordance with the National Fuel Gas Code, ANSI Z223.1.

In Canada: An individual manual shutoff valve must be installed in accordance with the B149.1, Natural Gas and Propane Installation Code. It is recommended that an individual manual shutoff valve be installed within 6 feet (1.8 meters) of the dryer.

Natural Gas Specifications**							
Nominal Heating Value	Supply Pressure	Gross Heat Input		Orifice Size*		Orifice (Injector) Quantity	Burner Pressure
		Btu/hr	kW	DMS	mm		
1,000	in wc	224,000	65.64	5	5.2197	2	in wc
	6.0-12.0						3.5

* Consult factory for elevations over 2,000 feet (609.6 meters) for correct burner orifice size(s).

** Btu rating for both tumblers.

Gas Connections

Inlet connection 3/4" M.N.P.T.

Inlet supply size 3/4" Pipe (minimum)

Piping/Connections

The dryer is provided with a 3/4" N.P.T. inlet pipe connection on top of the dryer. It is recommended that a gas shutoff valve be provided to the gas supply line of each dryer for ease in servicing.

The size of the main gas supply line (header) will vary depending on the distance this line travels from the gas meter. Specific information regarding supply line size should be determined by the gas supplier.

NOTE: Undersized gas supply piping can create a low or inconsistent pressure, which will result in erratic operation of the burner ignition system.

TYPICAL NATURAL GAS INSTALLATION

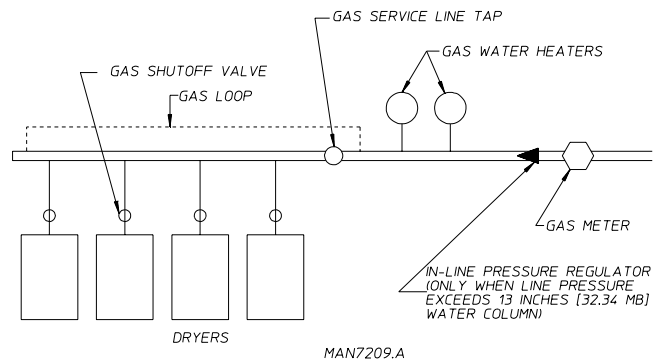

Consistent gas pressure is essential at all gas connections. It is recommended that a 3/4-inch (19.05 mm) pipe gas loop be installed in the supply line servicing a bank of dryers. An in-line pressure regulator must be installed in the gas supply line (header) if the (natural) gas pressure exceeds 13.0 in wc (32.34 mb) pressure.

A plugged tap, accessible for a pressure gauge connection, must be installed in the main gas supply line immediately upstream of the dryers.

IMPORTANT: Pipe joint compounds that resist the action of natural, propane, and butane gases must be used.

Test all connections for leaks by brushing on a soapy water solution (liquid detergent works well).

Preparation for Operation/Start-Up

The following items should be checked before attempting to operate the dryer:

- Read all "WARNING" and "DIRECTION" labels attached to the dryer.
- Check incoming supply voltage to be sure that it is the same as indicated on the data label.
- Be sure that all gas shutoff valves are in the open position.
- Be sure all back panels (guards) and electric box covers are in place.
- Be sure the service doors are closed and securely in place.
- Be sure the lint door/drawer is securely in place.
- Rotate the tumbler (drum) by hand to be sure it moves freely.
- Check bolts, nuts, screws, terminals, and fittings for tightness and security.
- Check that the vent is connected to the dryer and is exhausted to the outdoors.

Preoperational Test

All dryers are thoroughly tested and inspected before leaving the factory. However, a preoperational test should be performed before the dryer is publicly used. It is possible that adjustments have changed in transit or due to marginal location (installation) conditions.

Turn on electric power to the dryer.

Refer to the operating instructions for starting your dryer.

Open all shutoff valves.

When a gas dryer is first started (during initial start-up), it has a tendency not to ignite on the first ignition attempt. This is because the gas supply piping is filled with air, so it may take a few minutes for the air to be purged from the lines.

NOTE: During the purging period, check to be sure that all gas shutoff valves are open.

Tumbler Coating

The tumbler is treated with a protective coating. We suggest dampening old garments or cloth material with a solution of water and nonflammable mild detergent and tumbling them in the tumbler to remove this coating.

Microprocessor Programs/Selections

Each microprocessor controller (computer) has been preprogrammed by the factory with the most commonly used parameter (program) selections. If computer program changes are required, refer to the computer programming manual, which was shipped with the dryer.

Operating Instructions

The dryer is available for use when the appropriate side of the microprocessor display reads "0 minutes" and the amount needed to start the dryer (i.e., "25"). Once the load has been put into the dryer and the main door is closed, start the dryer as follows:

- Insert the proper number of coins into the coin acceptor. Once the correct "Amount To Start" has been inserted, the display will read "SELECT CYCLE".

- Determine fabric setting (selection).

Once the fabric temperature setting (selection) has been determined, start the dryer by pressing the fabric setting key.

- The dryer will now start, and the display will read the setting and the time vended.
- The cycle time will count down until the drying and cooling cycles are completed.
- Upon completion of the drying and cooling cycles, the dryer will shut off.

The dryer tumbler can be stopped at any time by opening the main door. To restart dryer, shut the main door and press desired setting.

NOTE: When a cycle is interrupted by opening the main door, cycle time will continue to count downward, regardless if the door is open or closed.

Selection (setting) changes can be made at any time during the drying cycle.

Shutdown Instructions

If the dryer is to be shutdown (taken out of service) for a period of time, the following must be performed:

Discontinue power to the dryer either at the external disconnect switch or the circuit breaker.

Discontinue the fuel supply: close external gas shutoff valve. Also close two internal gas shutoff valves.

Service/Parts Information

Service

Service must be performed by a qualified trained technician, service agency, or gas supplier. If service is required, contact the Maytag distributor from whom the equipment was purchased. If the distributor cannot be contacted or is unknown, contact the Maytag Co. for a distributor in your area.

NOTE: When contacting the Maytag Co., be sure to give them the correct model number and serial number so that your inquiry is handled in an expeditious manner.

Parts

Replacement parts should be purchased from the distributor from whom the Maytag equipment was purchased. If the distributor cannot be contacted or is unknown, contact the Maytag Co. for a distributor in your area.

NOTE: When ordering replacement parts from the Maytag distributor or the Maytag Co. be sure to give them the correct model number and serial number so that your parts order can be processed in an expeditious manner.

Routine Maintenance

A program should be established for the inspection and cleaning of lint in the burner area, exhaust ductwork, and area around the back of the dryer. The frequency of inspection and cleaning can best be determined from experience at each location.

Exhaust duct outlet should be checked periodically for blockages, and if any found, removed.

Cleaning

A program and/or schedule should be established for periodic inspection, cleaning, and removal of lint from various areas of the dryer, as well as throughout the ductwork system. The frequency of cleaning can best be determined from experience at each location. Maximum operating efficiency is dependent upon proper airflow. The accumulation of lint can restrict this airflow.

NOTE: Suggested time intervals shown are for average usage, which is considered 6 to 8 operational (running) hours per day.

Every 6 months, inspect the exhaust ducting and remove any lint buildup.

Suggested Cleaning Schedule

⚠ WARNING



Electrical Shock Hazard
Disconnect power before servicing.
Replace all parts and panels before operating.
Failure to do so can result in death or electrical shock.

Every Third or Fourth Load

Clean the lint screen every third or fourth load. A clogged lint screen will cause poor dryer performance. The lint door/drawer is located just below the loading door of the dryer. Open the lint door/drawer, brush the lint off the lint screen, and remove the lint. Inspect lint screen and replace if torn.

NOTE: To remove the lint drawer from the dryer first pull the screen out roughly half way and lift the clip on the lower left side of the lint drawer up. Now you will be able to pull the lint drawer completely out.

IMPORTANT: The frequency of cleaning the lint screen can best be determined from experience at each location.

Weekly

Clean lint accumulation from lint chamber, thermostat, and microprocessor temperature sensor area.

90 Days

Remove lint from gas valve burner area with a dusting brush or vacuum cleaner attachment.

Clean any lint accumulation in and around the motor(s) casing opening.

NOTE: To prevent damage, avoid cleaning and/or touching ignitor/flame-probe assembly.

Every 6 Months

Inspect and remove lint accumulation in customer furnished exhaust ductwork system and from dryer's internal exhaust ducting.

NOTE: Do not obstruct the flow of combustion and ventilation air. Check back draft dampers in the exhaust ductwork. Inspect and remove any lint accumulation, which can cause the damper to bind or stick.

A back draft damper that is sticking partially closed can result in slow drying and shutdown of heat circuit safety switches or thermostats.

When cleaning the dryer cabinet(s), avoid using harsh abrasives. A product intended for the cleaning of appliances is recommended.

Adjustments

7 Days After Installation and Every 12 Months Thereafter

Inspect bolts, nuts, screws, setscrews, grounding connections and nonpermanent gas connections (unions, shutoff valves, and orifices). Belts should be examined. Cracked or seriously frayed belts should be replaced. Complete an operational check of controls and valves. Complete an operational check of all safety devices (lint door/drawer switch, door switches, sail switch, and hi-limit thermostats).

Data Label Information

Standard Label

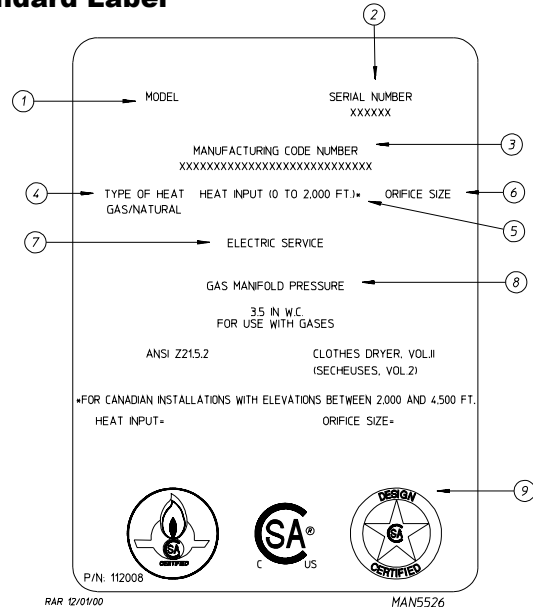

When contacting Maytag, the information on the data label is required to ensure proper service/parts assistance. The data label is located at the lower left rear of the dryer behind the back guard.

1. **Model Number** – This describes the style of dryer and type of heat (gas).
2. **Serial Number** – Allows the manufacturer to gather information on your particular dryer.
3. **Manufacturing Code Number** – The manufacturing code number is a number issued, which describes all possible options on your particular model.
4. **Type of Heat** – This describes the type of heat for your particular dryer, gas (natural gas).
5. **Heat Input** – This describes the heat input in British thermal units per hour (Btu/hr) or kilowatts (kW).
6. **Orifice Size** – Gives the number drill size used.
7. **Electric Service** – This describes the voltage and current rating for a particular model.
8. **Gas Manifold Pressure** – This describes the manifold pressure taken at the gas valve tap.
9. **Applicable Approval Seal(s)** – I.E., Canadian Standards Association International.

